



PE Sand Filter

1.5 Inch Top Mount Series



USER MANUAL

1. PE Sand Filter Parameters

Model	Pipe Size (inches)	Filter Area (m ²)	Design Flow (m ³ /h)	0.5-0.8mm Sand Weight (kg)	Tank Volume (m ³)	Valve Volume (m ³)	Tank Weight (kg)	Valve Weight(kg)
HT-PG350	1.5	0.10	4.50	25	0.06	0.02	4.0	3
HT-PG400	1.5	0.13	6.50	34	0.09	0.02	5.0	3
HT-PG450	1.5	0.16	8.00	50	0.15	0.02	6.5	3
HT-PG500	1.5	0.23	11.50	80	0.20	0.02	9.2	3
HT-PG650	1.5	0.32	16.00	160	0.32	0.02	12.1	3
HT-PG700	1.5	0.40	20.00	220	0.42	0.02	17.0	3

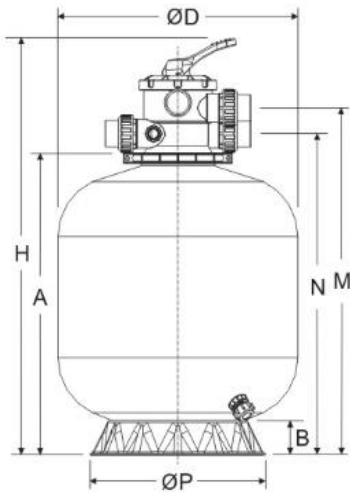

Model	HT-PG350	HT-PG400	HT-PG450	HT-PG500	HT-PG650	HT-PG700
ΦD(mm)	350	410	450	535	635	710
H(mm)	750	770	830	870	970	1040
B(mm)	75	75	75	75	95	95
A(mm)	490	510	570	610	710	780
ΦP(mm)	319	319	390	390	565	565
N(mm)	545	565	625	665	765	835
M(mm)	600	620	680	720	820	890

Maximum Working Pressure: 36psi/2.5kg/cm² (Plastic Clamp)
 Maximum Operation Water Temperature: 43°C (109°F)

2. Function

1) Hidrotermal's filters are mold blown into one piece of high density polyethylene. Our filters are corrosion-proof and safe for the users and the environment. Equipped with a 6-way multiport valve and a 360° clamp lock, whose allow trouble free installation and maintenance. An UV-resistant and chemical proof formula of high density polyethylene makes our filters reliable to work under direct sunlight during years of prolonged operations.

2) The filter uses special filter sand to remove dirt particles from pool water. The filter sand is loaded into the filter tank and functions as the permanent dirt removing media. When the control valve is in the FILTER position, the pool water which contains suspended dirt particles, is pumped through the piping system and is automatically directed by the filter control valve to the top of the filter tank. As the pool water is pumped through the filter, dirt particles are rapped by the sand bed, and filtered out. The cleaned Pool water is returned from the bottom of the filter tank, through the control valve and back to the pool through the piping system. This entire sequence is continuous and automatic and provides for total recirculation of pool water through the filter and piping system.

3) After a period of time the accumulated dirt in the filter causes a resistance to the flow, making it to diminish. This means it is time to clean your filter. With the control valve in the BACKWASH position, the water flow is automatically reversed through the filter so that it is directed to the bottom of the tank, up through the sand, flushing the previously trapped dirt and debris out the waste line. Once the filter is back-washed of dirt, set control valve to the RINSE position and run the pump for about 1/2 to 1 minute, then resume to normal filtering.

NOTE: Stop the pump before changing the valve position!

Please read and follow this MANUAL before install and use the filter!



3. Installation

Only simple tools (screwdriver and wrenches), plus pipe sealant for plastic adapters, are required to install and service the filter.

- 1) The filter should be placed on a reasonably level surface and provided adequate drainage. Position the filter so that the piping connections, control valve are convenient and accessible for operations and service, The filter should be placed as close to the pool as possible in order to reduce the line loss from pipe friction.
- 2) Loading the sand media. Filter sand media is loaded through the top opening for filter.
 - a. Loosen flange clamp and remove filter control valve (if previously installed).
 - b. Cap internal pipe with plastic cap to prevent sand from entering it.
 - c. We recommend filling tank approximately to half of it's water capacity. In order to provide a cushion effect when the filter sand is poured in. This helps protect the under-drain laterals from an excessive shock.
 - d. Carefully pour in the correct amount and grade of filter sand. (Be sure the center pipe remains centered in the opening.) The sand surface should be leveled and up to about the middle of the filter tank. Remove the plastic cap from the internal pipe.
- 3) Assemble the filter control valve to the filter tank.
 - a. Insert the filter control valve (with the O-ring in place) into the tank neck, be ware that the center pipe slips into the hole at the bottom of the valve.
 - b. Place two plastic clamps around the valve flange and tank flange and tighten just enough so that the valve may be rotated on the tank for final positioning.
 - c. Carefully screw the pressure gauge (with the O-ring in place) into the tapped hole on the valve body. Do not over-tighten.
 - d. Connect the pump to control the valve opening marked PUMP. After connections are made, tighten the valve flange clamp switch as screwdriver, tap around the clamp with a screwdriver handle to help seat the valve flange clamp.
- 4) Set a return to the pool pipe connection to control the valve opening marked RETURN and complete other necessary plumbing connections, suction as lines to the pump, waste, etc.
- 5) Perform the electrical connections to the pump following the pump manual.
- 6) Make sure all the pipe connections are tight and there are no leakages.

4. Filter's Start -Up

- 1) Make sure the correct amount of filter sand is in the tank and that all connections have been correctly made and secured.
- 2) Push the down control valve handle and rotate to the BACKWASH position. (To prevent any damage to the control valve seal, always push down the handle before turning.)
- 3) Start the pump according to the pump manual (Make sure all the suction and return lines are opened), allowing the filter tank to fill in with water. Once the water is flowing out it removes any fine sand particles and impurities from the sand media.
- 4) Stop the pump and set valve to the RINSE position. Start the pump and operate for 1 minute until water is clear. Stop the pump and set the valve to the FILTER position and then restart the pump. The filter is now operating at the normal filtering mode, removing dirt particles from the pool water.
- 5) Adjust the pool suction and the return valves to achieve desired flow. Check the system and the filter for water leaks and tighten the connections, bolts, nuts, as required.
- 6) Acknowledge the initial pressure gauge reading when the filter is clean. (It will vary from each pool depending on the pump and general piping system.) As the filter removes dirt and impurities from the pool water, the accumulation in the filter will cause the pressure to rise and the flow to diminish. When the pressure gauge reading is 1.5 BAR higher than the initial "clean" pressure you noticed, then it is time to backwash the filter (See BACKWASH under filter and control valve functions).

Note: During the initial clean-up of the pool water it may be necessary to backwash frequently due to the heavy initial dirt load in the pool.



5. PE Sand Filter Structure

1) Filter Replacement Parts

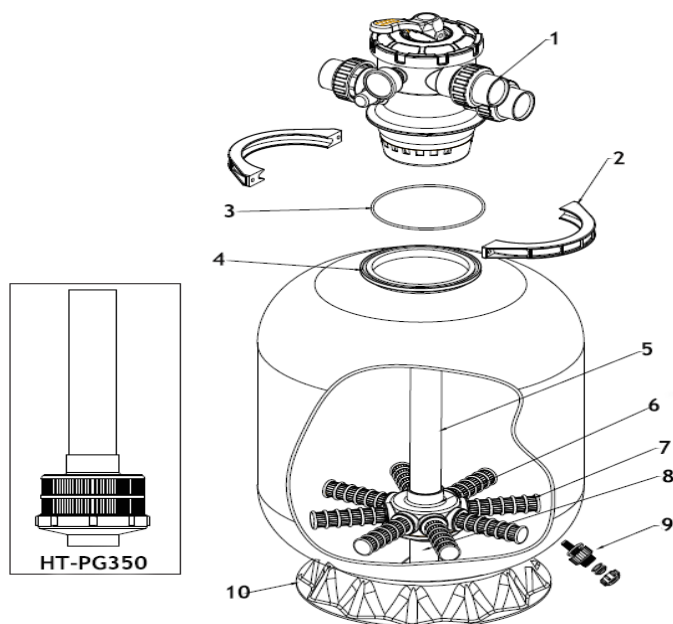

Key No.	Product Description	Qty
1	1.5" Top Mount Valve	1
2	Clip-L	1
	Clip-R	1
	Screw-clip	2
	Nut-clip	2
3	Gasket of Flange	1
4	Filter tank	1
5	Center pipe	1
6	Lateral Assembly	1
7	Lateral	8
8	Support pipe	1
9	Drain	1
10	Filter support stand	1

Figure 2

2) Multiport Valve Replacement Parts

Item No.	Product Description	Qty
1	Handle	1
2	Screw-handle	1
3	Washer for handle	1
4	Function point-out panel	1
5	Lid assy	1
6	Washer-plastic	2
7	Washer-Spring	2
8	Spring	1
9	Rotor	1
10	Spider Gasket	1
11	O-ring, lid	1
12	Body-diffuser assy	1
13	Bulkhead assy	3
14	Plug	1
15	Pressure gauge	1
16	Sight glass	1
17	Sight glass O-ring	1
18	Rotor	1
19	Over drain diffuser	1
20	O-ring filter	1
21	Clip	1
22	Screw-clip	2
23	Nut-clip	2

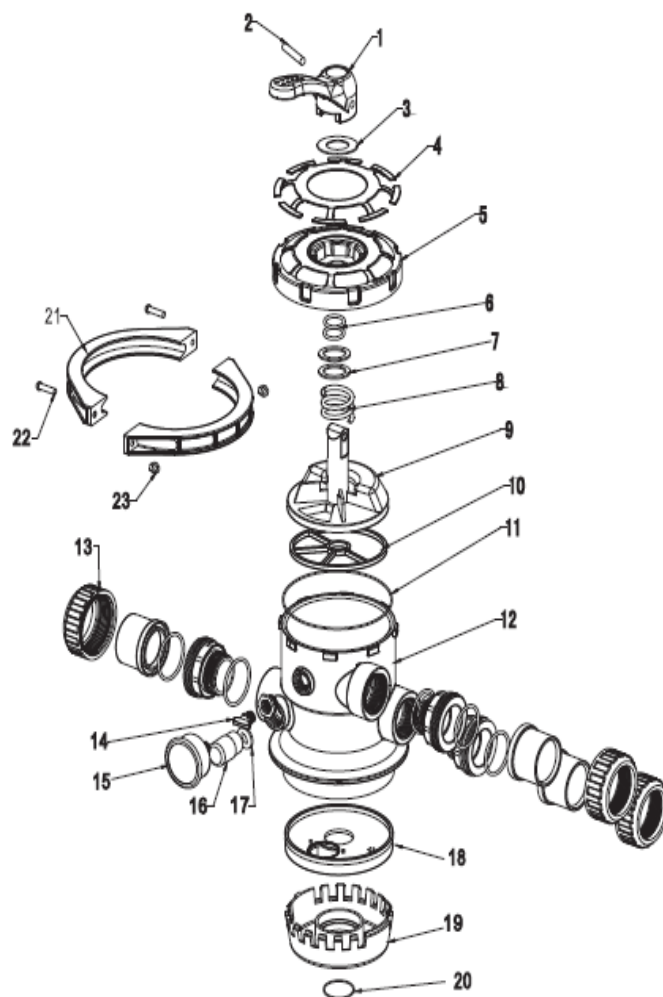

Figure 3

6. Trouble Shooting Guide

SYMPTOMS	PROBABLE CAUSES	ACTION TO BE TAKEN
Water leaks from handle position	1. the ring under the standard lid of handle is damaged. (Please see Figure 3, Item No. 3-Washer for Handle)	1. Replace item No.3 washer (Please see Figure 3)
Water leaks from the top lid of the filter	1. The O-Ring for 1.5"Valve rotor cover is not sealed well. (Please see Figure 3, Item No.7-Washer for spring)	1. Check if the washer for spring is sealed well and adjust it.
	2. Item No.7-Washer for spring is damaged.	2. Replace item No.7 washer for spring.(Please see Figure 3)
Sand media leaking from drain outlet	1. The sand media diameter is too small.	1. Check if the sand media diameter is too small or not.
	2. The laterals are damaged. (Please see Figure 2, item No.7-Laterals).	2. If water outlet pipe also leaking, that means the laterals are broken, please replace these. (See Figure 2, item No.7-Laterals)
Water leaks from drain outlet	1. The spider gasket is loose or damaged. (Please see Figure 3, Item No.10-Spider Gasket)	1. Check if the spider gasket is loose or not, adjust it.
		2. If it was damaged please replace it.(See Figure 3, Item No.10-Spider Gasket).

7. Valve Positions Function

Valve Position	Function
FILTER	Normal Filtration and Vacuum
BACK WASH	Clean Filter by reversing the flow
RINSE	Use after backwash to flush dirt from valve
WASTE	By-passes filter, use to vacuum the waster for lowering water level
RECIRCULATE	By-passes filter for circulating water to pool
CLOSED	Shut off all flow to filter or pool

FILTER

WASTE

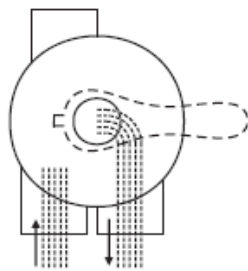

IN FLOW OUT FLOW

WASTE

WASTE

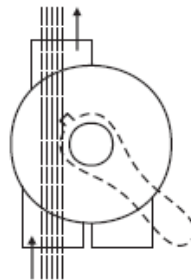

IN FLOW OUT FLOW

CLOSED

WASTE

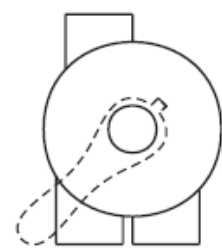

IN FLOW OUT FLOW

BACKWASH

WASTE

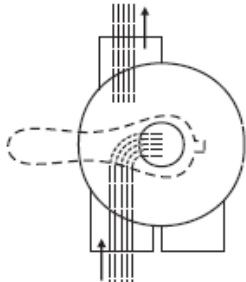

IN FLOW OUT FLOW

RINSE

WASTE

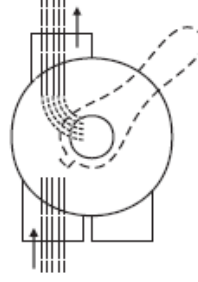

IN FLOW OUT FLOW

RECIRCULATE

WASTE

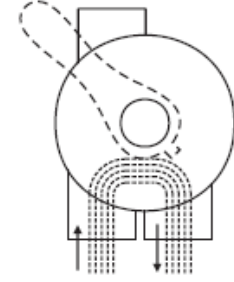

IN FLOW OUT FLOW

Function and Installation Scheme

I. Filtration of Medium (i.e. Water)

Pool => Pump => Valve (to filter) => filter => Valve (from filter) => Pool

III. No Circulation

Do not operate pump.
Pool => Pump => Valve

V. Recirculation of Fluid Without Filter (by pass filter)

Pool => Pump => Valve => Pool

II. Drainage of Pool with Pump

Pool => Pump => Valve => Canal

IV. Cleaning of Filter Medium (i.e. Sand) in upstream (reserved flow in filter)

Pool => Pump => Valve (from filter) => filter => Valve (to filter) => Waste

VI. Cleaning of Filter Medium (i.e. Sand) after Backwash

Pool => Pump => Valve (to filter) => filter => Valve (from filter) => Waste

Warning



1. THIS FILTER OPERATES UNDER HIGH PRESSURE. WHEN ANY PART OF THE CIRCULATING SYSTEM (e.g. CLAMP, PUMP, FILTER, VALVES, ETC.) IS SERVICED, AIR CAN ENTER THE SYSTEM AND BECOME PRESSURIZED. PRESSURIZED AIR CAN CAUSE THE LID OR VALVE TO BE BLOWN OFF WHICH CAN RESULT IN SEVERE INJURY, DEATH, OR PROPERTY DAMAGE.



2. TURN PUMP OFF BEFORE CHANGING VALVE POSITION.



3. TO PREVENT DAMAGE TO THE PUMP AND FOR PROPER OPERATION OF THE SYSTEM, CLEAN PUMP STRAINER AND SKIMMER BASKET REGULARLY.



4. DO NOT UNSCREW SCREWS OF FLANGE CLAMP WHILE PUMP IS RUNNING.

