



**WALL MOUNTED UNDERWATER (ULTRA FLAT RESIN FILLED) LED
SWIMMING POOL LIGHT**



HIDRO-PW200/HIDRO-PW200H

INSTALLATION AND MAINTENANCE MANUAL

Please read this operation manual carefully and keep it for future reference.



WARNING

1. Only a licensed or certificated electrician or a qualified serviceman is allowed to install or maintain this product.
2. Must be installed in accordance to the requirements of your government standard or local authorities.
3. Never handle it with wet hands and feet.
4. This light is design for use only when fully submerged in water.
5. Never operate this light for more than 1 minute unless it is totally submerged in water.
6. All lights are required to be disconnected from the main electricity before any operation of maintenance.
7. Maximum depth range for the light installation: 1-10 meter.
8. Maximum water temperature range for the light: -20°C-35°C

1. Technical Parameters

Standard Input Voltage: 12V / 24V

AC / DC

Standard Input Wattage:

SMD LED		High Power LED			
<input type="checkbox"/> 18W	<input type="checkbox"/> 30W	<input type="checkbox"/> 12W	<input type="checkbox"/> 18W	<input type="checkbox"/> 24W	<input type="checkbox"/> 30W

Dimension: $\Phi 220 \times 39\text{mm}$

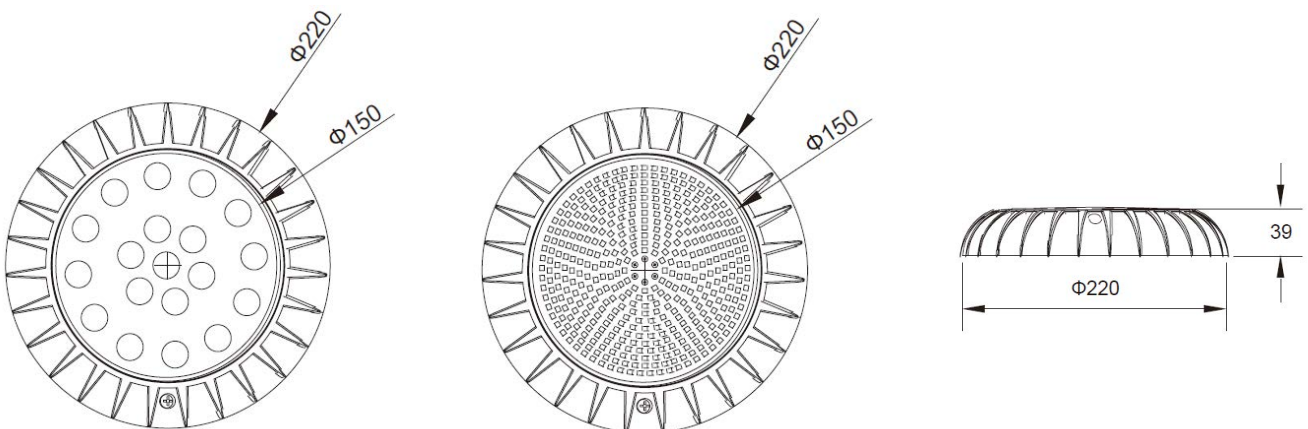

2. Installation

2.1 Preparing to Installation

1. Make sure the pool and its electrical system meets the requirements of the current national or local electrical codes and ordinances.
2. This light can be installed in both concrete pools and fiber glass pools.
3. This light is designed to be used in new pools and/or pools with existing surface mounted lights that need replacement.
4. Use only good quality stainless steel screws or screws provided along with the light.
5. The light must be used or operated while fully submerged underwater only. Never switch on the light if it is not underwater.

2.2 Installation Notes

1. Make sure to install the bracket on a vertical wall of the pool.
2. Make sure the top of the light should be at least 450mm below normal water surface.
3. Reserve at least 150mm long backup wire wrapping on the back of the light, for the convenience of replacing.
4. The junction box or the 12V low voltage transformer, should be located at least 300mm above the water surface, at least 200mm above the ground, and at least 1200mm from the edge of the pool.
5. To achieve synchronization, make sure all the lights are installed correctly on model and characteristics as the one being replaced.

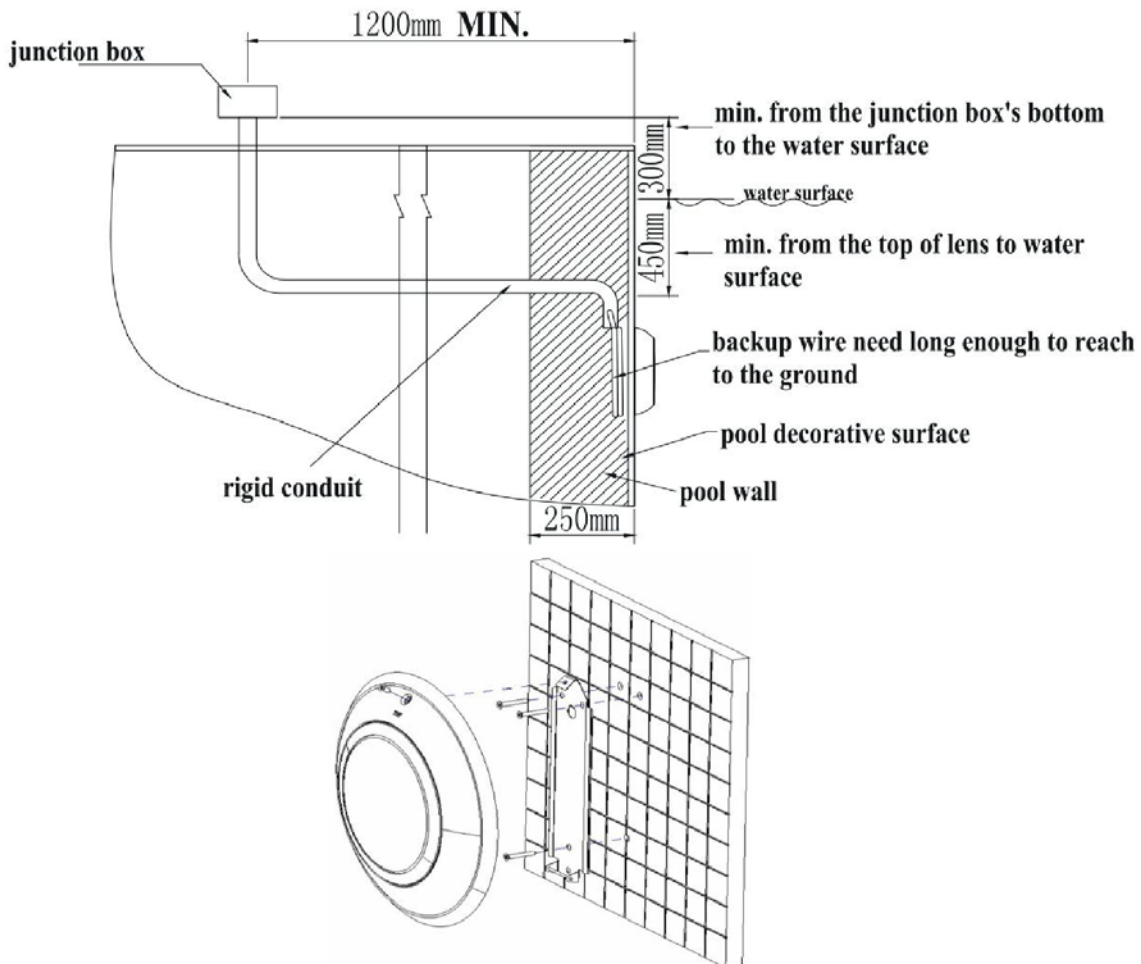

3. RGB Light Color Control Operation

16 pre-programmed color modes of RGB light:

1	BLUE: static blue	2	RED: static red
3	GREEN: static green	4	RB: static purple
5	BG: static cyan-blue	6	RG: static yellow
7	RGB: static white	8	RGB change gradually to R/G/B
9	R-G-RG slow animation	10	B-G-BG slow animation
11	R-B-RB slow animation	12	RB-BG-RG slow animation
13	R-G-B fast animation	14	B-G-R fast animation
15	Six colors fast animation	16	R-G-B slow animation

Remark: When the lights without internal controller option, the light programs will keep changing by fixed automatic cycle switch.

RGB Operation:

1. Any of the 16 modes can be selected with the ON/OFF switch of your pool lights.
2. Turn the light ON.
3. The 16 color modes will begin to run automatically.
4. To change the color, turn the light OFF and then ON within 15 seconds. Continue turning OFF and ON until the desired light color mode is reached. When the light is turned OFF for more than 1.5 seconds, it will return to the beginning of the color cycle (mode 0).

Remote Controller Options: There are 3 optional control ways

- 1) Power switch control, 2) Remote control (Hidro-CTRL), 3) synchrostep remote control

The color modes can also be selected with the controller. One remote control device can be adapted to 30 pool lights simultaneously within 100 meters.

4. Maintenance and Replacement

1. There is no maintenance required for this light. It is designed to be used only once, meaning that replacement is necessary if it becomes defective. The repairing is impossible.
2. Before servicing the light, always disconnect the power of the circuit breaker to it. Make sure there is NO voltage supplied to the light.
3. To replace the light, unfasten it from the bracket. Make sure the new light is the same switch.

5. Warranty

1. The manufacturer warrants this led underwater light against defect in materials and workmanship for a period of two (2) years from the date of purchase.
2. This warranty is limited to the first retail purchaser, it is not transferable, and does not apply to products that have been moved from their original installation sites. This warranty does not cover failures or malfunctions from improper installation and/or operation.
3. The manufacturer is not responsible in any circumstances for assembly, installation or start-up of any electric components which have been inserted or handled at locations other than its own premises.
4. The liability of the manufacturer shall not exceed the repair or replacement of defective parts. It specifically excludes liability for direct, incidental or consequential damages.